



# 590 Micro-Pneumatic™ Lead Cutter

The Xuron® Micro-Pneumatic™ Lead Cutter is the latest in advanced ergonomic design. Sized to fit readily in the operator's hand, it alleviates the fatigue and related CTDs (cumulative trauma disorders) associated with conventional wire cutter use. Easily actuated by light pressure with either the thumb or forefinger, the 590 Micro-Pneumatic™ quickly adapts to either right or left hand use.

Its design allows excellent maneuverability and access into restricted areas, a significant advantage with today's high density electronics packaging. It features quiet (<60 dbA) operation and is very light in weight (6 oz./ 160 grams), addressing two important fatigue factors. Cutter heads, which are treated with a non-glaring black finish for excellent contrast with the work surface, also promote reduced eye strain.

The cutter heads feature Micro-Shear® cutting action for ultra-clean, ultra-flush cuts. They are manufactured from high carbon steel and heat treated to a Rockwell hardness of 58-59C; for exceptional durability. The 590 Micro-Pneumatic™ is rated for soft wires less than 1 mil. All the way up to 16 AWG and is suitable for cutting a variety of other materials, including plastics.

The tool's design offers quick and easy cutter head replacements. It operates from a dry, unlubricated 50 PSI air-line, consuming just 0.13 cubic feet of air per minute of operation.

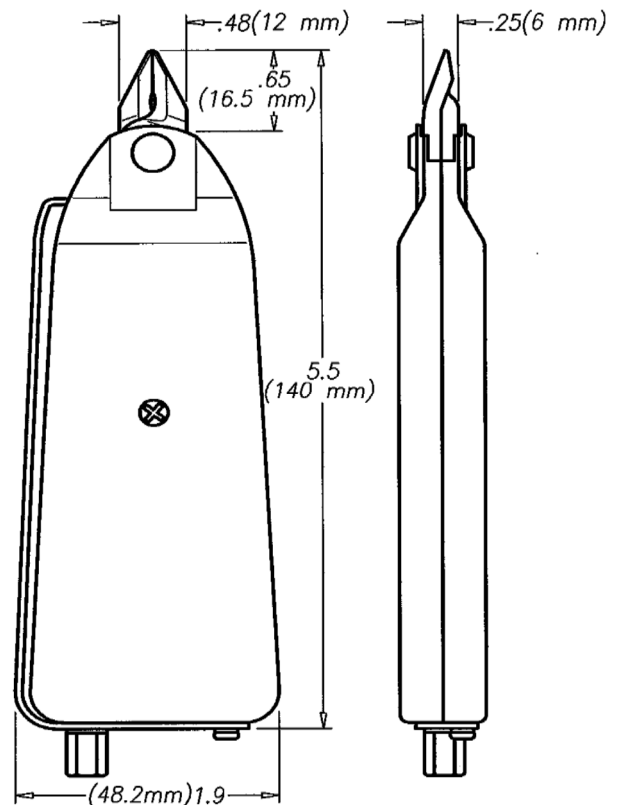
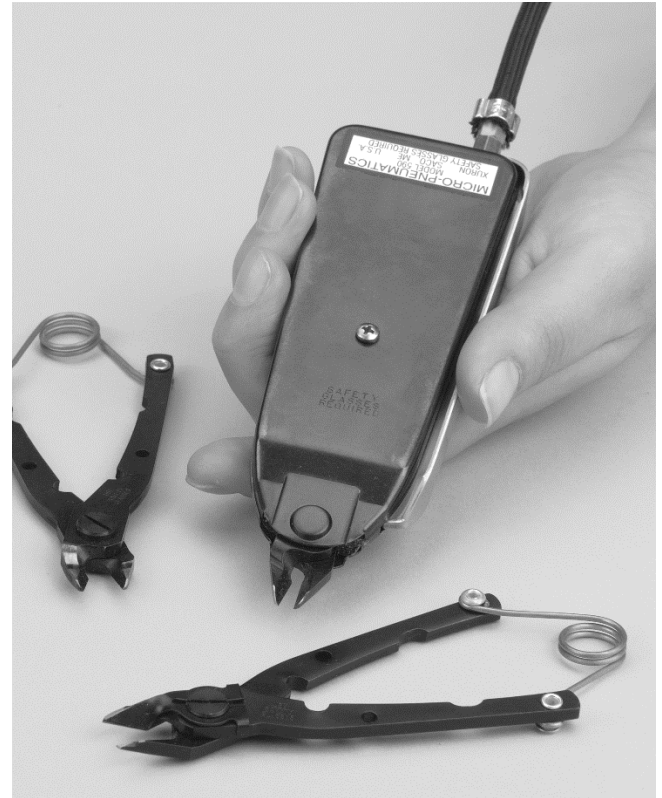

## SPECIFICATIONS

Length	5.5"	139mm
Width	1.5"	38mm
Thickness	0.6"	15mm
Weight	6 oz.	160 grams
Length of Cut	0.35"	9 mm
Operating Pressure	50 PSI max.	3.4 ATM
Maximum Capacity	0.050/ 16 AWG Soft	1.27mm Soft wire

### Instruction Sheet

#### BLADE REPLACEMENT

1. Disconnect hose assembly from air source.
2. Remove screw on nameplate side. **Leave red screws in place.**
3. Carefully remove top housing by working a small screwdriver between the top and bottom housing on the side opposite the actuator (6).
4. Remove the blade and vane assembly from case. Remove blade from vane assembly.
5. Install new blade by reversing the order in which the old blade was removed.
6. Replace the top housing being careful to avoid pinching the bellows.
7. Replace the screw.

#### BELLOWS REPLACEMENT

1. See "Blade Replacement" steps 1 – 3.
2. Slip bellows feed tubes from valve tubes with small screwdriver, fingernail or tweezers. Be careful to avoid damaging the valve tubes.
3. Remove bellows from housing.
4. Replace new bellows by reversing the manner in which the old bellows were removed.
5. See "Blade Replacement" steps 6 – 7.

#### VALVE INSTALLATION

1. **To avoid damage to the valve (11), assemble with all items in place as shown.**
2. Use minute amount of Loctite #609 on male threads of threaded adaptor. Too much Loctite will lock the valve.

#### HOSE ASSEMBLY/ DISASSEMBLY

1. Hold threaded adaptor (14) with wrench while attaching or removing hose. Use fiber gasket supplied.

**Warning:** Use Safety Glasses.

#### **Cautions:**

1. Maximum operating pressure of 50 PSI. Initial application of pressure may cause activation of tool.
  2. Assembly of valve without proper spacers or correct parts and fasteners as shown will result in damage to the valve.
  3. Do not use lubrication in valve or air-line.
- A reconditioning/ refurbishing service is available from the factory. Please contact your distributor for details.

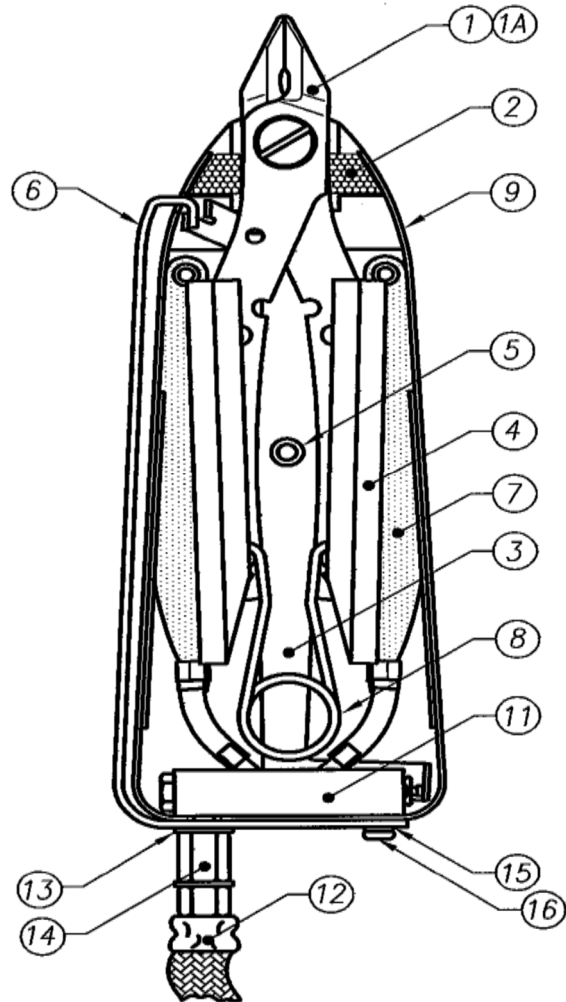

ITEM	DESCRIPTION	PART NO.	QTY
1	Cutter Head	P40230	1
1A	Cutter Head w/ Lead Retainer # 590-F	P40230F	1
2	Foam Seal Set	P10110	2
3	Linkage	P10100 Rev C	1
4	Vane Set	P10540	2
5	Post	P1000 Rev D	1
6	Actuator	P10090 Rev B	1
7	Bellows Assembly	P40220	2
8	Spring & Eyelet Set	P10510	1
9	Bottom Housing (shown)	P10050 Rev B	1
10	Top Housing (not shown)	P10190 Rev B	1
11	Valve Complete	P40240	1
12	Hose w/ Fiber Gasket	P40040	1
13	Spacer	P10400	1
14	Threaded Adapter	P10410	1
15	#2 Lockwashers	F10210	2
16	#2 Screw	F10020	1
17	Cutter Head – Low-profile (not shown)	P40230LP	1

Note: all replacement blades include springs.